

MOBILE TRANSCEIVER

model RC 660 TR

TECHNICAL DESCRIPTION

1. EQUIPMENT SPECIFICATION

1.1 General

Service

Single or double frequency simplex

Frequency ranges

RC660-TR-A	68 MHz to 88 MHz
RC660-TR-M	(105 MHz to 108 MHz - transmitter 138 MHz to 141 MHz - receiver)
RC660-TR-D	116 MHz to 136 MHz
RC660-TR-H	156 MHz to 174 MHz

Channel separation

50 kHz, 25 kHz or 12.5 kHz are standard, other separations can be supplied to special order.

Number of channels

Up to four channels, grouped within any 1 MHz portion of the frequency range. 10 channels to special order.

Aerial impedance

50 ohms, unbalanced.

Control facilities

Local control on the front panel of the unit only.

Power supply

Nominally $12.6 \pm 10\%$ volts d.c., although no damage will be incurred by a supply level of 16V.

Current drain

Receive (muted)	250 mA
Transmit	1.5 A

Ambient temperature range

Operational	-10°C to +55°C
Storage	-25°C to +70°C

Weight

With tray	4 $\frac{1}{4}$ lb (1.9 kg)
Without tray	4 lb (1.8 kg)

Dimensions

Length (overall)	9 in (22.9 cm)
Width with tray	8 in (20.3 cm)
without tray	6.8 in (17.3 cm)
Height with tray	2.2 in (5.6 cm)
without tray	1.9 in (4.8 cm)

Approval

The equipment has been type approved to G.P.O. performance specifications W6600 (25 kHz channel spacing) and W6770 (12.5 kHz channel spacing).

1.2 Transmitter

Power output

RC660-TR-A, M and H, 4 to 7 watts c.w. with 12.6 volts from the power supply.

Modulation

Amplitude modulation with automatic gain control to limit peak modulation to 90%.

Modulation response

300 Hz to 2000 Hz (12.5 kHz channel spacing).

Spurious emissions

Less than 2.5 micro-watts at any frequency separated by more than 50 kHz from the carrier frequency.

Frequency stability

Between $\pm 0.001\%$ and $\pm 0.003\%$, dependent upon frequency band of operation and minimum channel separation required.

1.3 Receiver

Signal-to-noise ratio

Better than 10 dB for an r.f. input of $1.6 \mu\text{V}$ e.m.f. modulated 30% at 1000 Hz on all bands and all channels.

Sensitivity

More than 2 watts audio output into 15 ohms, for an r.f. input of $1.6 \mu\text{V}$ e.m.f. modulated 30% at 1000 Hz.

Audio distortion

With an r.f. input of 1 mV e.m.f. modulated 30% at 1000 Hz, distortion is less than 10% at the 2 watts audio output level.

Audio response

300 Hz to 2000 Hz (12.5 kHz channel spacing).

Automatic gain control

Less than 6 dB change of audio output for a variation of r.f. input from 10 μ V to 10 mV e.m.f. (30% modulation at 1000 Hz).

Mute threshold

Adjustable for r.f. input levels of 0.8 μ V e.m.f. to 5 μ V e.m.f.

Spurious responses

Less than 10 dB signal-to-noise ratio for an r.f. input of 3 mV e.m.f. at any frequency separated by more than 25 kHz from the receiver channel frequency.

Intermediate frequency

10.7 MHz.

Intermediate frequency filter responses

Filters for 50 kHz channel spacing:

- 3 dB bandwidth of \pm 15 kHz minimum
- 90 dB bandwidth of \pm 50 kHz maximum

Filters for 25 kHz channel spacing:

- 3 dB bandwidth of \pm 7.5 kHz minimum
- 80 dB bandwidth of \pm 25 kHz maximum

Filters for 12.5 kHz channel spacing:

- 3 dB bandwidth of \pm 3.75 kHz minimum
- 80 dB bandwidth of \pm 12.5 kHz maximum

Frequency stability

Between \pm 0.001% and \pm 0.003%, dependent upon frequency band of operation and minimum channel separation required.

2. CIRCUIT DESCRIPTION

2.1 Transmitter (Fig. 4.1)

2.1.1 Master oscillator and frequency multiplier

Four fundamental mode quartz crystals in the base-emitter circuit of transistor VT207, are used to control the frequency of a Colpitts type oscillator, the appropriate crystal being selected by the CHANNEL switch S2C. The selected crystal resonates in series with two fixed capacitors C230 and C231 and a parallel combination of fixed and variable capacitance, which is adjusted to compensate for the frequency tolerances of the crystal.

Positive feedback in the base-emitter circuits of transistor VT207 maintains the resonant circuit in oscillation. The collector of the oscillator is impedance matched into two mutual inductance coupled circuits, inductors L217 and L216, which are tuned to select the second harmonic of the crystal frequency.

2.1.2 Frequency multipliers

The output from the oscillator-multiplier bandpass circuit is transformer coupled into two parallel-connected transistors VT205 and VT206. This stage, together with its associated double tuned bandpass circuit L215 and L214, is operated as a class B frequency doubler for low and mid band v.h.f. operation and as a frequency trebler for high band v.h.f. operation. The following stage, comprising transistors VT204 and VT208 together with an associated double tuned bandpass circuit, is operated as a class B frequency doubler, the output being at the desired carrier frequency. The total frequency multiplication is:

x8 for low and mid band v.h.f. operation
and x12 for high band v.h.f. operation

2.1.3 Carrier frequency amplifiers

The output from the frequency multipliers is processed through three stages of power amplification and frequency selection. The first stage VT203 and the driver stage VT202 are each class B grounded emitter amplifiers with capacitance tapped, single tuned, interstage coupling circuits. Inductors L210 and L207 form part of the tuned circuits, whereas inductors L211, L209, L208 and L206 are r.f. chokes to complete the d.c. circuits only. Circuit tuning and impedance matching is effected by variable capacitors C216, C215, C213 and C211.

Power amplifier VT201 is impedance matched into a bandpass filter by variable capacitors C208 and C206. The filter accepts the whole operational frequency band and has an out-of-band attenuation characteristic which reduces harmonic outputs to negligible proportions. Its output impedance matches the impedance of the 50 ohms aerial circuit.

2.1.4 Modulation and a.g.c.

To prevent sustained over modulation of the carrier, an automatic gain control (a.g.c.) is included in the voice-frequency signal path from the microphone to the audio amplifier. The final sections of this amplifier are common to both the transmitter and the receiver and its circuit is described in para. 2.2.10.

The voltage developed across a winding of the audio output transformer T1, is rectified by the diode D2 to produce a positive d.c. voltage proportional in amplitude to the modulation signal level. This d.c. is resistance-capacitance smoothed and applied through a preset level control RV6 to the base-emitter circuit of transistor VT24.

When the modulation level increases beyond a threshold level determined by the setting of RV6, transistor VT24 conducts, attenuating the modulation signal by introducing the components C87 and R106 across the modulation signal path.

Audio power is fed from the output winding of transformer T1 in series with the power supply to the driver and power amplifier to amplitude modulate the transmitter output.

2.2 Receiver (Figs. 4.2 - 4.4)

2.2.1 Radio frequency amplifier

A double tuned bandpass circuit couples the signal from the aerial into the two stage r.f. amplifier, transistors VT1 and VT3, where it is amplified before injection into the mixer. Double tuned bandpass circuits effect interstage coupling within the amplifier, and between the amplifier and the mixer stage VT4. Maximum amplification is applied to small input signals, whilst for large signals the amplifier gain is reduced by an a.g.c. potential applied to the base electrodes of both r.f. transistors.

The amplifier bandwidth is nominally 0.5 MHz for low v.h.f. band sets and 1 MHz for mid and high v.h.f. band sets.

2.2.2 Receiver oscillator and frequency multiplier

Transistor VT2 operates in a crystal oscillator circuit which is similar to that of the transmitter master oscillator described in para. 2.1.1. The appropriate crystal is selected by the channel switch S2B. A double tuned bandpass circuit in the output of the oscillator selects the second harmonic of the crystal frequency for low v.h.f. band operation. For mid and high v.h.f. band operation, the fourth harmonic of the crystal frequency is selected.

The frequency-multiplied output from the oscillator is transformer coupled into the base of transistor VT5, where the collector is connected to a double tuned bandpass circuit, which selects the second harmonic of the stage input frequency and couples it into the emitter circuit of the mixer. The total frequency multiplication is:

x6 for low band v.h.f. operation
and x12 for mid and high band v.h.f. operation.

2.2.3 Mixer

The amplified r.f. signal and the output from the frequency multiplier are heterodyned together in the mixer stage VT4 to produce an intermediate frequency of 10.7 MHz. The mixer frequency relationships are expressed as follows:

$$f_{i.f.} = f_c - 6 f_o \text{ for low band}$$

$$f_{i.f.} = 12 f_o - f_c \text{ for mid band}$$

$$\text{and } f_{i.f.} = f_c - 12f_o \text{ for high band}$$

where f_o is the oscillator crystal frequency,

f_c is the radio carrier frequency and

$f_{i.f.}$ is the intermediate frequency, 10.7 MHz.

2.2.4 Crystal filter and i.f. amplifier

At the mixer output, resistor R20 and capacitor C32 effect an impedance match into the crystal filter FL1. This block filter is an eight-crystal lattice configuration, and its insertion loss characteristic determines the acceptance bandwidth and adjacent channel attenuation of the receiver. Resistor R111 adjusts the impedance matching from the filter output into the four-stage intermediate frequency amplifier, comprising transistors VT6, VT7, VT12 and VT13. Two tuned circuits limit the noise bandwidth of the amplifier and improve out-of-band selectivity.

2.2.5 Detector

Amplitude modulation of the i.f. signal is detected by the non-linear characteristic of transistor VT15 when biased to near collector current cut-off by adjustment of the variable resistor RV2. There are three separate outputs from the detector at the collector of VT15:

- (a) The detected audio signal.
- (b) A reduction of the positive d.c. voltage at the collector of VT15, proportional to the level of c.w. drive into the detector.
- (c) A level of noise proportional to any man-made interference at the input of the receiver.

2.2.6 Noise limiter

The audio signal from the detector passes through the series noise-limiting diode D3 to the VOLUME control RV4, and hence to the input of the audio amplifier at the base of transistor VT20. Diode D3 is normally biased to conduct, and is switched to its non-conducting state by any impulse noise having an amplitude in excess of a percentage level of modulation which is pre-set to be between 30% and 40%.

2.2.7 Automatic gain control

The d.c. from the collector of the detector is smoothed and applied via the a.g.c. emitter follower amplifier to control the bias of transistors VT1, VT3, VT6, VT7 and VT8, and reduce the gain of these stages as the i.f. signal drive into the detector increases.

2.2.8 Muting circuit

The detector d.c. output is also routed through a high resistance R77 to transistor VT23 at the input to a three stage d.c. amplifier. The output stage, VT26, shares a common load resistor, R84, with the emitter of the audio amplifier input transistor VT20. When conducting, the current through VT26 is of sufficient magnitude to bias the audio transistor VT20 to cut-off, thereby muting the receiver output.

For any given r.f. input level into the receiver of between 0 and 8 μ V e.m.f., the level into the d.c. amplifier can be adjusted by variable resistor RV7 to mute the receiver so that a 2 dB increase of signal level at the receiver input will cause the mute to open. Positive d.c. feedback, from the collector of the audio transistor VT20 through resistor R103 to the base of VT26, increases the speed of mute switching and reduces "backlash" to a minimum.

Variable resistor RV8 provides fine adjustment of the mute threshold, and is available at the front of the unit for use by the operator.

2.2.9 Muting circuit noise compensation

Impulse interference noise causes a change in detector current capable of operating the mute circuit in a manner similar to an incoming signal. To prevent this happening, noise at a frequency above the audio frequency is selectively amplified by transistors VT19, VT21 and their associated tuned circuits, rectified by diode D4 and applied to the input of the d.c. amplifier (VT23) with a polarity designed to balance out detector current changes caused by impulse noises. Variable resistor RV5 provides balance adjustment of the circuit.

2.2.10 Audio frequency amplifier

The audio amplifier, from the relay changeover contacts RL2A to the audio power transformer T1, is used for both receiver audio and transmitter modulation amplification purposes. Its circuit is of conventional design with three cascaded common emitter stages of amplification, transistors VT20, VT18 and VT16, followed by a phase splitter VT14, working into a push-pull emitter follower impedance transforming stage VT10 and VT11, which drives the push-pull audio power amplifier VT8 and VT9.

A low pass filter, comprising inductor L17 and capacitors C70, C72 and C75, connected between the first and second stages, determines the amplifier high frequency cut-off and rate of attenuation of frequencies above 3 kHz.

The gain of the amplifier is stabilised by negative feedback from the output winding of transformer T1 through C34 and R26 to the base of VT16. The supply voltage to the first four stages is stabilised by Zener diode D1, its range of control being adjustable by variable resistor RV1.

2.3 Receive-transmit Switching

All receive to transmit switching functions are carried out by two relays, RL1 and RL2, which are energised when the "press-to-talk" switch on the hand microphone is depressed. Changeover contacts on these relays perform the following switching functions:

RL1A - switches capacitance to decouple the receiver input whilst transmitting.

RL1B - aerial circuit, receiver to transmitter changeover.

RL1C - connects the power supply to the transmitter oscillator and multipliers, when transmitting.

RL1D - not used.

RL2A - switches the audio amplifier input from the receiver detected output to the output from the microphone pre-amplifier.

RL2C - breaks the power supply to the receiver r.f., i.f. and detector circuits, when transmitting,

RL2B and RL2D - speaker/modulator changeover switching.

MAINTENANCE

1. ROUTINE MAINTENANCE

In order to maintain the radio installation in good working order, it is recommended that the following checks should be made each month, and corrections carried out as necessary.

1.1 Initial Checks

With the equipment switched off, check that:

- (a) Connections between the equipment and the vehicle's battery supply leads are secure and free from corrosion.
- (b) The two fuses in the battery supply leads are intact and of the correct rating (5A).
- (c) Plugs and sockets in the speaker and aerial leads are correctly and securely mated.
- (d) The aerial feeder connections to the aerial base bracket and the aerial terminal are secure.
- (e) The security of mechanical fixings of
 - (i) the transmitter-receiver unit in its mounting cradle
 - (ii) the mounting cradle
 - (iii) the microphone holder
 - (iv) the loudspeaker
 - (v) the aerial base and the aerial.

1.2 Electrical Checks

Carry out the following electrical and operational checks:

- (a) Switch the equipment on by rotating the VOLUME control clockwise, and observe that the indicator lamp illuminates.
- (b) Rotate the MUTE control and check that
 - (i) when fully clockwise the receiver is muted,
 - (ii) the mute threshold occurs in the centre region of control rotation,

- (iii) when fully counter-clockwise the receiver is not muted.
- (c) With the receiver unmuted check that the rotation of the VOLUME control correctly adjusts the level of sound from the speaker, and that the control is free of track noise and any discontinuities.
- (d) Connect an ammeter in series with one of the supply leads to the equipment, and check that
 - (i) when operating on receive (muted), the current is in the region of 250 mA
 - (ii) the current increases to approximately 1.5A when transmitting c.w. and increases further when speaking or whistling into the microphone.
- (e) Adjust the MUTE control to just mute the receiver and establish a test communication with another station in the system; check that satisfactory two way speech can repeatedly be established.
- (f) If the equipments operate on more than one channel, the two previous operations should be repeated on all channels.
- (g) On completion of these checks, remove the ammeter from the supply lead and make good the connection from the equipment to the vehicle.

2. BASIC FAULT FINDING

2.1 General

There are three basic conditions of a faulty radio installation; these are:

- (a) Both the transmitter and the receiver operate incorrectly or not at all.
- (b) The transmitter functions correctly, but the receiver functions incorrectly or not at all.
- (c) The receiver functions correctly, but the transmitter functions incorrectly or not at all.

When faults are localised to the transmitter-receiver unit and its microphone assembly or the loudspeaker unit, remove the faulty item from the installation and return it to a service workshop for

investigation and repair. If the fault is found to be in the installation cabling or connections, then it can be repaired in situ or the defective part can be replaced.

2.2 Faulty Transmitter and Receiver

2.2.1 Reduced power

When two way communication is possible, but with a very reduced range, the fault may be in the power supply system, the connections to the aerial or the aerial switching relay in the transmitter-receiver unit. To localise the fault, check:

- (a) Battery voltage is $12.6V \pm 10\%$.
- (b) Current consumption of the equipment is:

receive current	250 mA
transmit current	1.5 A.
- (c) If the current consumption is abnormal, switch the equipment off; if the input current falls to zero, the fault is within the transmitter-receiver unit. If the current is still flowing into the circuit then the fault is in the power supply cabling of the installation.

2.2.2 Loss of communication

When two way communication is lost completely, the fault may be in the power supply system; in this case the indicator lamp at the front of the transmitter-receiver will be either extinguished or dim. To localise the fault, break the supply lead connections at the fuse holders and measure the resistance across the two supply leads into the transmitter-receiver unit with the unit switched on. A resistance of greater than 150 ohms or less than 30 ohms will indicate a fault in the transmitter-receiver unit. A resistance reading between 30 and 150 ohms indicates that the set is probably operational, that the installation wiring is at fault, in which case check:

- (a) Battery voltage is $12.6V \pm 10\%$
- (b) Cabling from the fuse holders for open or short-circuit or high resistance conditions.
- (c) Fuses for continuity.
- (d) Good contact between fuse caps and holders.

2.3 Equipment Failure

2.3.1 Failure to receive

When the transmitter functions normally and the receiver does not respond to base station transmission, or produce a noise output from the loudspeaker when the MUTE control is adjusted fully counter-clockwise, the fault will be in the receiver or the loudspeaker. To localise the fault, unplug the loudspeaker from the cable harness and check that the resistance of the loudspeaker is approx. 12 ohms. A click will normally be heard when making this test if the loudspeaker is not faulty.

2.3.2 Failure to transmit

When the receiver functions normally but the transmitter does not, the fault will be in the transmitter-receiver unit or its attached microphone assembly. The repeated operation of a faulty transmitter may result in the introduction of additional faults.

3. TEST AND ALIGNMENT PROCEDURE

3.1 General

The comprehensive servicing and re-alignment of the transmitter-receiver unit, requires the use of the test equipment listed in para. 3.2, or equivalent instruments.

If servicing and alignment facilities are not available locally to the user, then the equipment should be sent for servicing to:

For the attention of the Service Department,
GEC-AEI (ELECTRONICS) LTD.,
Spon Street,
Coventry CV1.3AZ.,
England.

3.2 Test Equipment

- (a) Avometer Model 8, or Selectest Multimeter.
- (b) R.F. power output meter, 50 ohms impedance and 10 watts measurement capability at frequencies up to 200 MHz, e.g. Dymar r.f. power output meter, Type 781, or equivalent.
- (c) A.F. signal generator, 300 ohms impedance, frequency range 100 Hz to 10 kHz minimum, e.g. Dymar l.f. signal generator Type 741, and a 300 ohm matching pad, or equivalent.

- (d) V.H.F. millivoltmeter, capable of measuring up to 2 volts at frequencies up to 200 MHz, e.g. Type 711, or equivalent.
- (e) Modulation meter, e.g. Airmec Type 210, or equivalent.
- (f) General purpose cathode ray oscilloscope (c.r.o.).
- (g) V.H.F. signal generator, e.g. Marconi Type 995A/5, or equivalent.
- (h) L.F. valve voltmeter, e.g. Dymar Type 701, or equivalent.
- (j) 10.7 MHz reference oscillator having an accuracy and stability of frequency within ± 100 Hz, e.g. Dymar 10.7 MHz crystal oscillator, or equivalent.
- (k) Standard frequency measuring equipment having a minimum accuracy and stability of ± 1 part in one million, e.g. Telemex TD1, or equivalent.
- (l) Stabilised d.c. power supply, 10V to 16V variable, 3A, e.g. Roband Type 171, or equivalent.
- (m) A.F. power output meter, e.g. Marconi Type 893 or 893A, or equivalent.

3.3 Routine Functional Tests

The routine functional tests given in the succeeding paragraphs may be performed whilst the equipment is in its protective case, either as a workshop bench test with the unit powered by the stabilised power d.c. unit, para. 3.2 (1), or in the vehicle installation operating from the vehicle battery.

3.3.1 Preliminary

- (a) Connect the test instruments to the equipment to be tested as follows:
 - (i) the Avometer para. 3.2 (a), in series with one of the equipment supply leads to measure the operating supply current input to the unit
 - (ii) the equipment power supply leads to the stabilised d.c. power supply, para. 3.2 (1), taking care to observe the correct polarity of the connections
 - (iii) r.f. power output meter, para. 3.2 (b), to the aerial lead from the equipment (for transmitter tests)

- (iv) a.f. power output meter, para. 3.2 (m), and c.r.o., para. 3.2 (f), to the loudspeaker output from the unit (PL1), and set the impedance of the meter to 15 ohms.
 - (v) v.h.f. signal generator, para. 3.2 (g), to the aerial output socket (for receiver tests).
- (b) Set up test conditions as follows:
- (i) voltage of the stabilised d.c. power supply, para. 3.2 (1), to 12.6V
 - (ii) the equipment MUTE control to its fully counter-clockwise position.
- (c) Switch on the equipment by rotating the VOLUME control clockwise and check that:
- (i) the supply current is in the region of 250 mA
 - (ii) the indicator lamp is illuminated
 - (iii) the receiver noise can be seen on the c.r.o.
- (d) Set the v.h.f. signal generator, para. 3.2 (g), controls as follows:
- (i) r.f. output level to $10\mu\text{V}$ e.m.f.
 - (ii) amplitude modulation to a level of 30% at a frequency of 1000 Hz
 - (iii) radio frequency to the appropriate channel frequency, and adjust the fine tuning to set the signal frequency as near as possible to the centre of the receiver pass band, by observing the output on the power output meter and the c.r.o.

3.3.2 Receiver (Figs. 4.2 - 4.6)

- (a) With the VOLUME control adjusted to set the power output to 4 watts, check that the waveform on the c.r.o. is reasonably free from limiting and distortion.
- (b) Sensitivity. Measure the sensitivity by reducing the r.f. signal input level to $1.6\mu\text{V}$ e.m.f., and then checking that the audio power output is more than 2 watts. Adjust the VOLUME control for a power output of 1 watt.

- (c) Signal plus noise-to-noise ratio. With the conditions as established in (b), check that the audio power output reduces by more than 10 dB when the signal modulation is switched off.
- (d) Mute and automatic gain control. Re-establish the 30% modulation and 1 watt audio power output, and proceed as follows:
 - (i) adjust the MUTE control to just mute the receiver, and check that the receiver opens when the signal generator r.f. output is increased to $2\mu\text{V}$ e.m.f.
 - (ii) rotate the MUTE control fully clockwise, and check that the r.f. input now required to just open the mute does not exceed $10\mu\text{V}$ e.m.f.
 - (iii) increase the r.f. input level up to 100 mV e.m.f. and check that over the input variation from $1.6\mu\text{V}$ e.m.f. to 100 mV e.m.f., the audio output power level does not change by more than -3 dB or +6 dB.

3.3.3 Transmitter (Fig. 4.1)

- (a) Substitute the r.f. power output meter, para. 3.2 (b), in place of the v.h.f. signal generator in the aerial lead. Operate the transmitter by depressing the push switch on the hand microphone, and check that:
 - (i) the current from the power supply into the equipment is in the region of 1.5A
 - (ii) the transmitter power output, measured with the r.f. power output meter, para. 3.2 (b), is not less than 4 watts.
- (b) Check that the r.f. power output increases above the c.w. level when speaking or whistling into the microphone.

3.4 Circuit Alignment Procedures

3.4.1 General

The information contained in the following paragraphs will aid the service engineer in localising faults to a particular stage, to adjust circuit conditions and, if necessary, to completely re-align all circuits.

The test connections described in paragraph 3.3.1 of this Section are also applicable to these tests.

To gain access to the various circuit test points and pre-set adjusters, remove the top and bottom covers of the transmitter-receiver unit and refer to the component layout diagrams, (Figs. 4.1, 4.5, 4.6), for their location.

3.4.2 Test points

The test points provide monitoring sites for alignment and fault finding purposes, the measuring instrument being connected between the appropriate test point and the nearest convenient point on the negative supply line.

The following measurements may be made at the test points:

- (a) Test Point 1
The r.f. output voltage level from the transmitter oscillator-multiplier.
- (b) Test Point 2
The r.f. output voltage level from the first multiplier stage of the transmitter.
- (c) Test Point 3
The r.f. output voltage level from the second multiplier stage of the transmitter.
- (d) Test Point 4
The level of r.f. voltage into the transmitter driver stage.
- (e) Test Point 5
The level of r.f. voltage input to the transmitter power amplifier stage.
- (f) Test Point 6
The r.f. output voltage level from the receiver oscillator multiplier.
- (g) Test Point 7
The r.f. voltage level from the frequency multiplier VT5 into the mixer VT4.
- (h) Test Point 8
The r.f. voltage output of the r.f. amplifier; also a low frequency signal may be injected here for stage measurements.

- (j) Test Point 9
The d.c. voltage at the a.g.c. line.
- (k) Test Point 10
The a.f. voltage input to the audio amplifier; also audio signals may be injected here.
- (l) Test Point 11
The d.c. voltage of the stabilised supply to the receiver.
- (m) Test Point 12
The d.c. voltage of the supply input to the equipment.
- (n) Test Point 13
This is a link which is removed to facilitate the measurement of current through Zener diode D1 when making adjustments to the stabilised supply.

3.4.3 Stabilised supply line

- (a) With the equipment switched off, remove the link connection at Test Point 13 and connect the Avometer across the test point, to measure d.c. current up to 100 mA.
- (b) Set the supply voltage into the equipment to 13.6V, switch on the equipment and adjust RV1 to obtain 42 mA current through the multimeter.
- (c) Check that:
 - (i) when the power supply voltage is increased to 16 volts, the metered current does not exceed 100 mA
 - (ii) when the power supply voltage is reduced to 11 volts, the metered current is not less than 1 mA.

If necessary RV1 should be re-adjusted to achieve these conditions.

- (d) Switch off the equipment, reconnect the link at Test Point 13 and set the power supply voltage to 12.6V for the remainder of tests.

3.4.4 Audio amplifier (Figs. 4.4 - 4.6)

- (a) Connect the a.f. signal generator, para 3.2 (c), to Test Point 10.
- (b) Connect Output Meter and e.r.o. to loudspeaker cable.
- (c) Set the VOLUME control RV4 fully clockwise.
- (d) Set the MUTE control RV8 fully counter-clockwise.
- (e) Check that it is possible to increase the signal input level to obtain 5 watts output.

3.4.5 I.F. amplifier (Figs. 4.3, 4.5, 4.6)

- (a) Set the preset control RV5 fully clockwise.
- (b) Set the preset control RV2 to mid-position.
- (c) Set the preset control RV3 fully clockwise with its rotating contact just on the carbon track.
- (d) Connect the v.h.f. signal generator, set to a frequency of 10.7 MHz, amplitude modulated 30% at 1000 Hz, across the output terminals of the crystal filter FL1.
- (e) Increase the output level from the v.h.f. signal generator to obtain an audio frequency power output in the region of 50 mW, and adjust the cores of inductors L11 and L12, in a direction away from the printed circuit board, to optimise the output.
- (f) Check that a $10\mu\text{V}$ e.m.f. input signal, modulated 30% at 1000 Hz, produces an audio output of 4W minimum.

3.4.6 Receiver oscillator and multipliers (Figs. 4.2, 4.5, 4.6)

- (a) Set the CHANNELS switch S2 to select the channel nearest to the mean of the highest and lowest channel frequencies.
- (b) Connect the v.h.f. millivoltmeter to Test Point 6, and adjust the cores of inductors I5 and I6 to optimise the measured voltage on the first peak which occurs when moving the cores from the level of the printed circuit. A typical voltage measurement with the circuits aligned is 400 mV.

- (c) Connect the v.h.f. millivoltmeter to Test Point 7, and optimise the measured voltage by adjusting the cores of inductors I9 and I10. For low band sets, select the first peak when moving the cores away from the printed circuit, and select the second peak when aligning mid and high band sets. A typical voltage measurement with the circuits aligned is 50 mV.
- (d) Check that the voltage at Test Point 7 is in the region of 50 mV on all other operational channels.

3.4.7 R.F. amplifier

- (a) If the circuits have not been previously aligned, commence with the cores of inductors L1, L2, L3, L4, L7 and L8 positioned level with the top of the coil formers for mid and high band sets, and close to the bottom of the former for low band sets. Select the operating channel as in para. 3.4.6 (a).
- (b) Connect the v.h.f. signal generator to aerial socket SK1 and adjust its frequency to the required channel, amplitude modulated 30% at 1000 Hz. Set the signal level to an appropriate value, (10 mV or more), and tune the signal into the receiver.
- (c) Set the signal level of the signal generator to give audio power output to approximately 100 mW, and adjust the cores of inductors L1, L2, L3, L4, L7 and L8 for maximum audio power output, progressively reducing the input signal level to prevent overloading. Loosely couple the 10.7 MHz reference oscillator, para 3.2 (j), into the receiver i.f. circuit and tune the signal generator frequency for zero beat frequency at the receiver output, then remove the reference oscillator.
- (d) Set the signal level to 1.6 μ V, switch off the modulation and then carefully adjust the core of L2 for minimum noise power indication on the audio power output meter.
- (e) Re-establish the 30% modulation, adjust the power output to 50 mW, then measure signal-to-noise ratio by removing the modulation and checking that the audio power output reduces by more than 10 dB.

3.4.8 Noise Limiter

- (a) With test conditions as in 3.4.7 set the output level of the v.h.f. signal generator to 16 μ V e.m.f., modulation to 30% at 1000 Hz.

- (b) Connect c.r.o. to Test Point 14.
- (c) Observing the audio output waveform on the c.r.o., adjust the variable resistor RV2 to set one of the peaks of the waveform on the threshold of limiting.
- (d) Back off RV2 slightly and re-check signal-to-noise ratio as in 3.4.7.

3.4.9 Automatic gain control setting

- (a) Set level of v.h.f. signal generator modulated 1000 Hz, 30% to $1.6\mu\text{V}$ and adjust variable resistor RV4 to set the audio power output to 50 mW.
- (b) Increase r.f. signal to 100 mV and check that the output does not increase by more than 10 dB. Adjust RV3 if necessary.

3.4.10 Mute circuit adjustment

- (a) Tune the signal into the receiver using the 10.7 MHz reference oscillator to establish the correct on-tune frequency, as described in para 3.4.7 (d).
- (b) Switch the carrier of the v.h.f. signal generator off, and establish the following:
 - (i) rotate the variable resistor RV5 fully clockwise
 - (ii) rotate the MUTE control RV8 fully counter-clockwise
 - (iii) adjust variable resistor RV7 to obtain the threshold of mute operation, then set RV7 so that the receiver output is just not muted.
 - (iv) adjust RV8 to obtain the threshold of mute operation
- (c) Switch the signal generator carrier on, set the r.f. signal level to $1.6\mu\text{V}$ e.m.f. modulated 30% at 1000 Hz, and check that the mute opens.
- (d) Reduce the r.f. input signal level by 2 dB and adjust the variable resistor RV5 to again just mute the receiver output.
- (e) Check that increasing the r.f. signal level to $1.6\mu\text{V}$ e.m.f. causes the receiver output to reappear. If the receiver output does not reappear then adjust RV5 until it does.

- (f) Increase r.f. signal to $4\mu\text{V}$ e.m.f. and set RV8 fully clockwise. Check that mute opens. RV_1 may be re-adjusted if necessary.
- (g) With RV8 set fully counter clockwise, and no r.f. signal applied, the set should be unmuted.

3.4.11 Receiver oscillator frequency adjustment

Use the standard frequency measuring equipment to accurately establish the required channel frequency input signal to the receiver, loosely couple the 10.7 MHz reference oscillator into the i.f. circuit of the receiver and adjust the appropriate variable capacitor, in series with the channel crystal, to set the beat frequency at the receiver output to less than 100 Hz.

The various channel adjustments are:

- (i) channel 1, adjust C91
- (ii) channel 2, adjust C105
- (iii) channel 3, adjust C17
- (iv) channel 4, adjust C9

3.4.12 Transmitter alignment (Fig. 4.1)

- (a) Substitute the r.f. power output meter in place of the v.h.f. signal generator in the aerial lead.
- (b) Adjust supply voltage to 12.0 V for RC660-TR or to 12.5 V for RC660-TRP.
- (c) Set the CHANNEL switch S2 to select the channel nearest to the mean of the highest and lowest channel frequencies.
- (d) Connect the v.h.f. millivoltmeter to Test Point 1, operate the microphone P/T ("press-to-transmit") switch and adjust the cores of inductors L216 and L217 for maximum voltage indication, this being typically 1.0V to 1.5V a.c. r.m.s.

NOTE: The core adjustments should be made by starting with the cores flush with the chassis and then adjusting away from the chassis to select the first voltage maximum for low and mid band sets and the second voltage maximum for high band sets. If peak of tuning is not clearly defined in steps (d), (e) and (f) then the supply voltage may be reduced by up to $\frac{1}{2}$ volt.

- (e) Connect the v.h.f. millivoltmeter to Test Point 2, operate the microphone P/T switch and adjust the cores of L214 and L215 for maximum voltage indication, using the method detailed in the note of operation (d). This is typically 2 to 3 V.
- (f) Connect the v.h.f. millivoltmeter to Test Point 3, operate the microphone P/T switch and adjust the cores of L212 and L213 for maximum voltage indication, using the method detailed in the note of operation (d). This is typically 2 to 2.5 V.
- (g) Set the supply voltage to 13.6 V for RC660-TR and RC660-TRP if used with internal batteries, or set supply voltage to 12.5 V for RC660-TRP if used with external supply.
- (h) Connect the v.h.f. millivoltmeter to Test Point 4, operate the microphone P/T switch and adjust variable capacitors C216 and C215 for maximum voltage indication. This is typically 1.5 to 2 V.
- (j) Observing the power output meter, adjust C213, C211, C208 and C206 for maximum power output initially. Readjust C213, C211, C208 and C206 to give the highest power output compatible with the meter showing and increase of approx. $\frac{1}{2}$ W when modulation is applied to the transmitter (e.g. whistle into microphone). A decrease in power output when modulation is applied should be avoided, or in the very worst case limited to a 0.1 W variation. Power outputs with no modulation (supply set to 13.6 V) should exceed:
 - (i) 4.5 W for low and mid band sets
 - (ii) 4.0 W for high band sets

3.4.13 Modulation level

- (a) Connect the a.f. signal generator to the blue (high) and white (low) wires at the equipment end of the microphone cable.
- (b) Loosely couple the modulation meter to the r.f. output meter.
- (c) Connect the c.r.o. to the I.F. output terminals of the modulation meter.
- (d) Adjust variable resistor RV6 approximately to its mid position.
- (e) Set the frequency of the a.f. signal generator to 1000 Hz.
- (f) Operate the microphone "press-to-transmit" switch and adjust the level of output from the a.f. signal generator to obtain 50% amplitude modulation of the transmitter output.

- (g) Readjust variable capacitors C216, C215, C213, C211, C208 and C206 for maximum transmitter power output.
- (h) Adjust the a.f. signal generator output to obtain 50% amplitude modulation of the transmitter and check that:
 - (i) the voltage from the a.f. signal generator does not exceed 7 mV.
 - (ii) the modulation envelope is reasonably free from distortion.
 - (iii) the unmodulated transmitter power output exceeds 5 W on all channels of low and mid band sets, and 4 W on all channels of high band sets.

3.4.14 Modulation level control

Proceeding from para. 3.4.13 (h) with the a.f. signal generator output level set for 50% amplitude modulation of the transmitter, increase the a.f. signal generator output level by 20 dB and adjust variable resistor RV6 to set the modulation to between 80% and 85%.

3.4.15 Transmitter frequency adjustment

Loosely couple the transmitter output into the standard frequency measuring equipment, para. 3.2 (k), and set the standard frequency to the required channel frequency. Operate the microphone "press-to-transmit" switch and adjust the appropriate variable capacitor in series with the channel crystal to set the channel frequency to within ± 100 Hz of the standard channel frequency.

The various channel adjustments are:

- (i) for channel 1, adjust C101
- (ii) for channel 2, adjust C99
- (iii) for channel 3, adjust C97
- (iv) for channel 4, adjust C95

4. SERVICE AND REPAIR

4.1 Dismantling

The top and bottom covers of the transmitter receiver unit are each fixed by four screws and washers, the removal of which allows the covers to be taken from the unit.

All receiver components, together with all channel crystals and their associated trimmer capacitors, are mounted on a single-sided printed circuit board. It is not necessary to remove the board from the main frame to gain access to components.

The transmitter oscillator, frequency multiplier and amplifier circuits are arranged on a sub-unit which is fixed to one edge of the main framework of the set. To release the sub-unit from its assembled position, remove the two screening covers from the sub-unit, disconnect the interconnecting wires at the sub-unit end, and then remove the two screws, (one from each end of the sub-chassis).

4.2 Repair

When removing components from the printed circuit, a high heat soldering iron should be used to rapidly heat the joint to the point where the solder flows freely and then remove the solder with a suction device. This operation should be completed as quickly as possible so that the iron does not remain on the joint any longer than is necessary to melt the solder.

Breaks in the printed wiring can be repaired by bridging the gap with solder or by soldering a short length of bare tinned copper wire across the gap.

When it is necessary to replace crystals, any component part of a tuned circuit, or a component part of a circuit requiring preset adjustment, the associated circuit or circuits should be realigned in accordance with the instructions given in this manual.

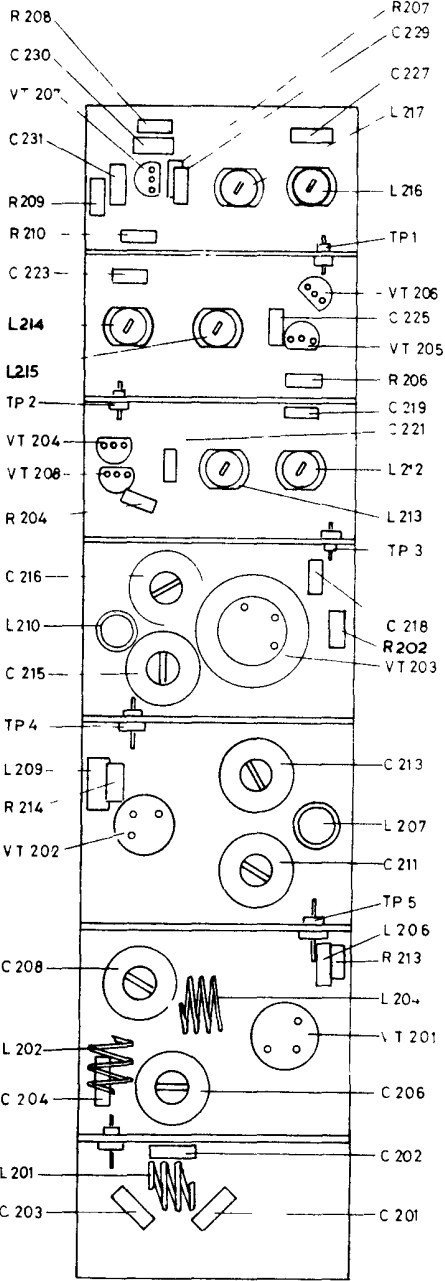

LOW BAND

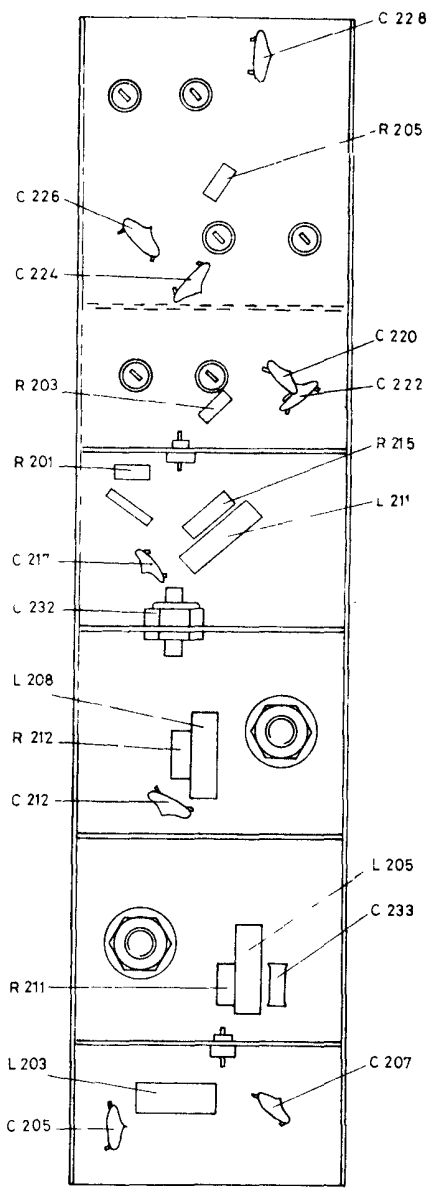

LOW BAND

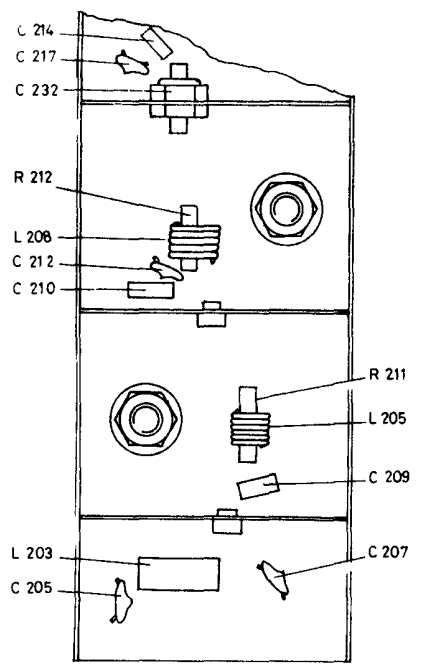

HIGH BAND

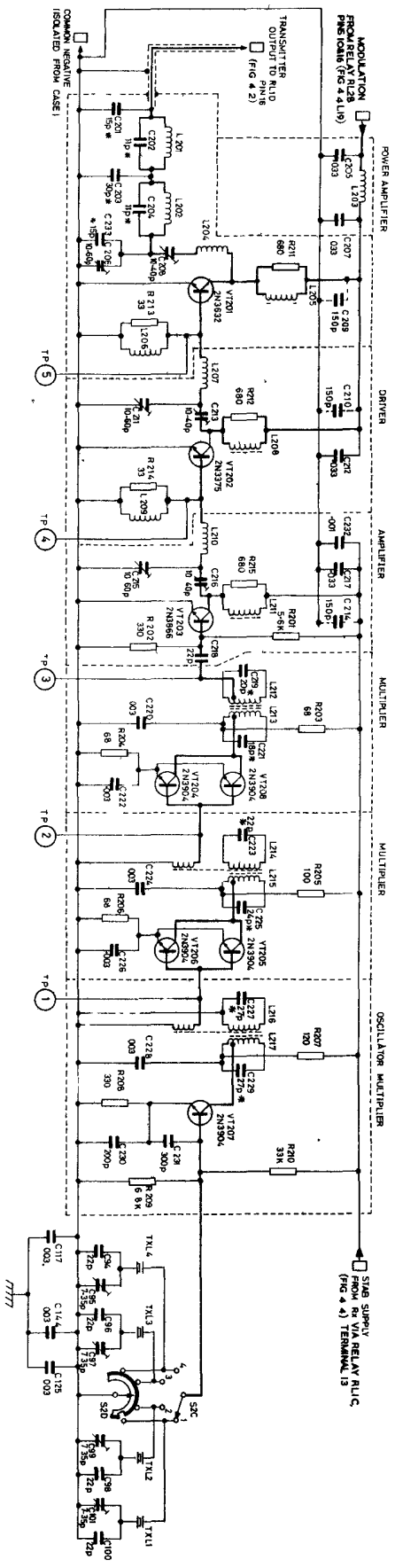

- NOTES
1. LOW BAND CIRCUIT SHOWN IS FOR A LOW BAND SET 68 MHZ TO 88MHZ. C208 C210 AND C214 ARE NOT USED ON LOW BAND SETS.
 2. HIGH BAND COMPONENT VALUES SHOWN ASTERISKED ARE NOT COMPATIBLE WITH HIGH BAND SET FOR APPROPRIATE VALUES SEE SECTION 5.
 3. V1700 R113 AND R214 ARE NOT USED ON HIGH BAND SETS.

FIG 4.1
TRANSMITTER

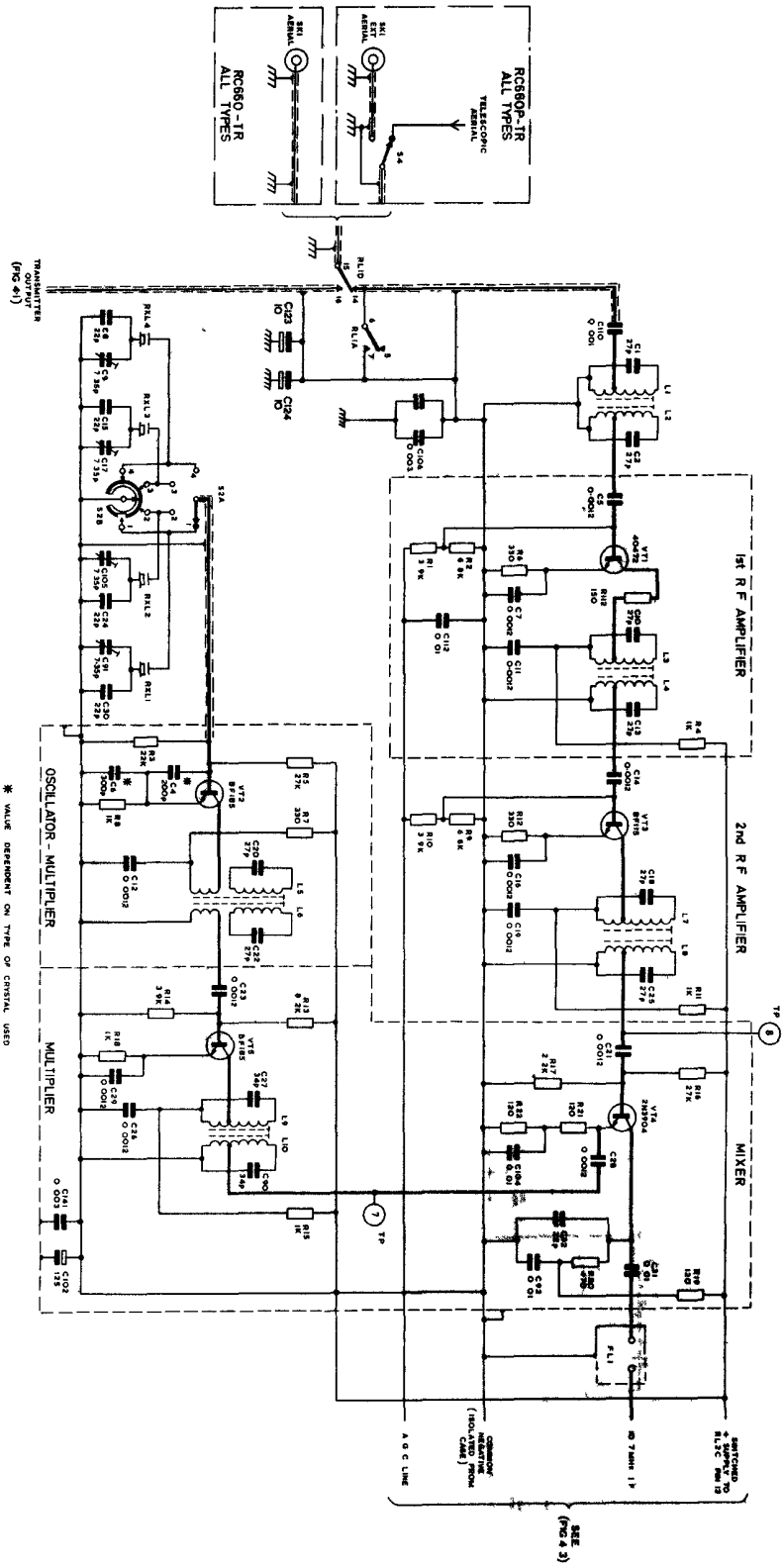

FIG 42
RECEIVER R AND LO STAGES

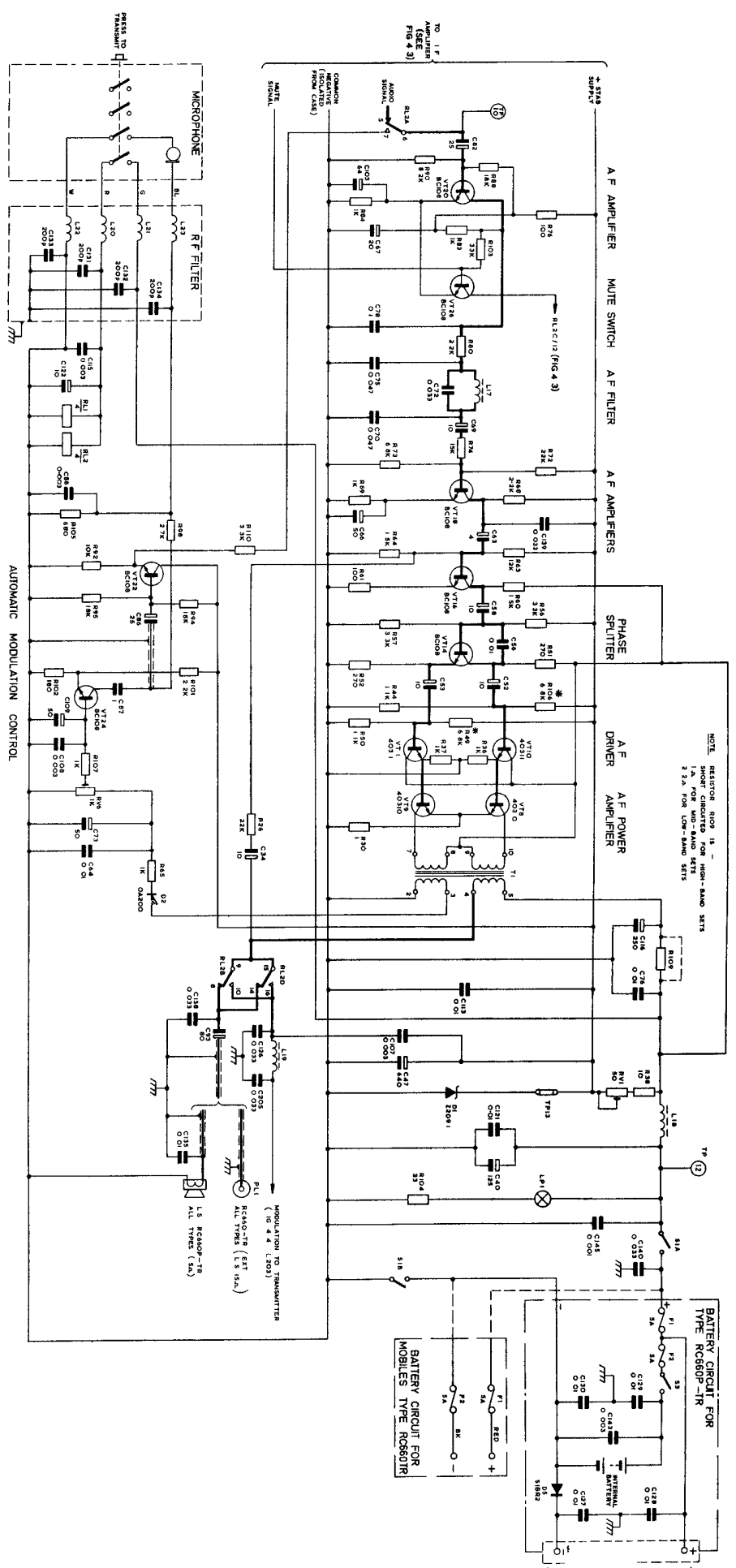

FIG 4.4
 RECEIVER A.F. AMPLIFIER

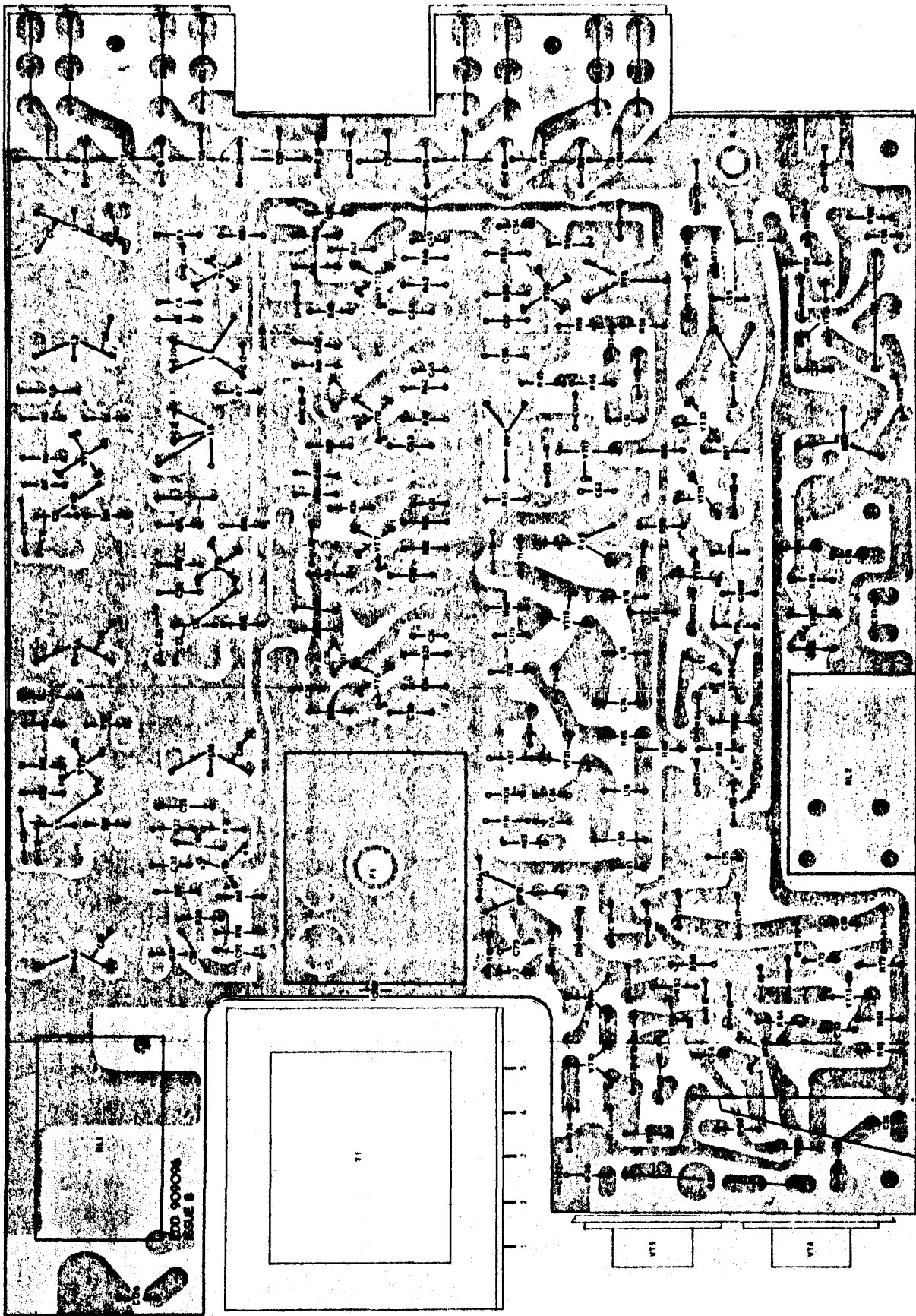
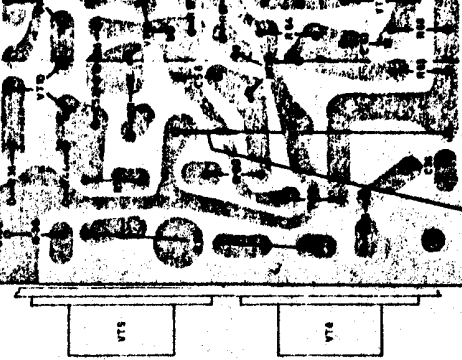
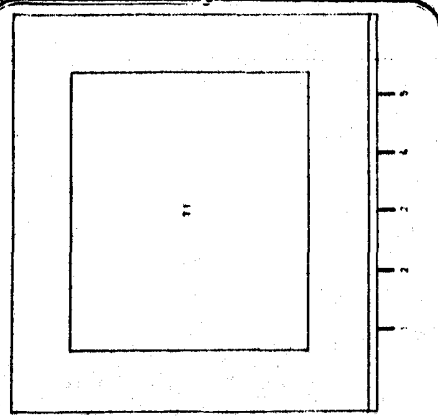
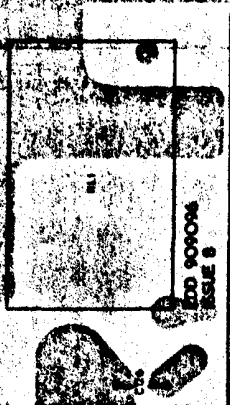

FIG. 1
RECEIVER BOARD: TOP



V7A, V7B, V7C, V7D, V7E, V7F, V7G, V7H, V7I, V7J, V7K, V7L, V7M, V7N, V7O, V7P, V7Q, V7R, V7S, V7T, V7U, V7V, V7W, V7X, V7Y, V7Z

V7A, V7B, V7C, V7D, V7E, V7F, V7G, V7H, V7I, V7J, V7K, V7L, V7M, V7N, V7O, V7P, V7Q, V7R, V7S, V7T, V7U, V7V, V7W, V7X, V7Y, V7Z

V7A, V7B, V7C, V7D, V7E, V7F, V7G, V7H, V7I, V7J, V7K, V7L, V7M, V7N, V7O, V7P, V7Q, V7R, V7S, V7T, V7U, V7V, V7W, V7X, V7Y, V7Z

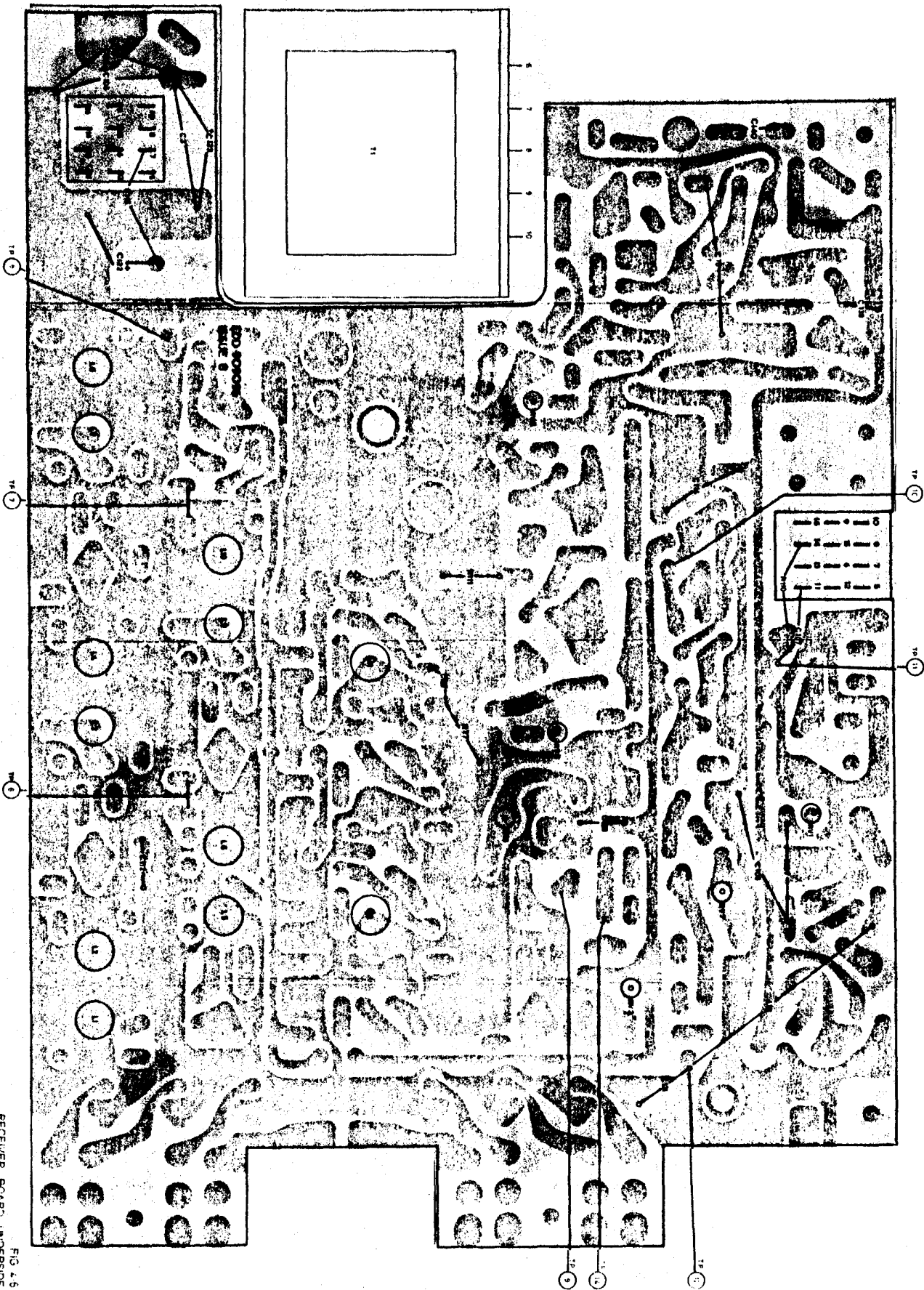

FIG. 4.5
RECEIVER BOARD, UNDERSIDE